

## PC Card (PCMCIA) Dual Interface Switch

### Features

- Single SO-16 Package
- CMOS Logic Compatible Inputs
- Smart Switching
- Slow  $V_{CC}$  Ramp Times
- Extremely Low  $R_{ON}$
- Supports Dual PC Card Slots
- Reverse Blocking Switches
- Low Power Consumption
- Safe Power-Up

### Description

The Si9707DY offers an integrated solution for dual PC Card power interfaces that require only  $V_{CC}$  switching. This part is ideal for systems that operate at 5 V and provide  $V_{PP}$  from the main supply, or from a dedicated Flash RAM 12-V supply.

that would short 5 V to the 3.3-V supply. This protection logic also allows the Si9707DY to be configured for positive or negative control logic for compatibility with a variety of PC Card controllers. These control inputs are CMOS logic compatible and can be driven to 3.3 V or 5 V.

The Si9707DY operates off the 5-V supply with built-in level shifting. The  $V_{CC}$  outputs function independently and internal logic protects each slot against a control logic error

The PC Card Dual Interface Switch is available in a SO-16 narrow-body package and is rated over the industrial temperature range of  $-40$  to  $85^{\circ}\text{C}$ .

### Functional Block Diagram

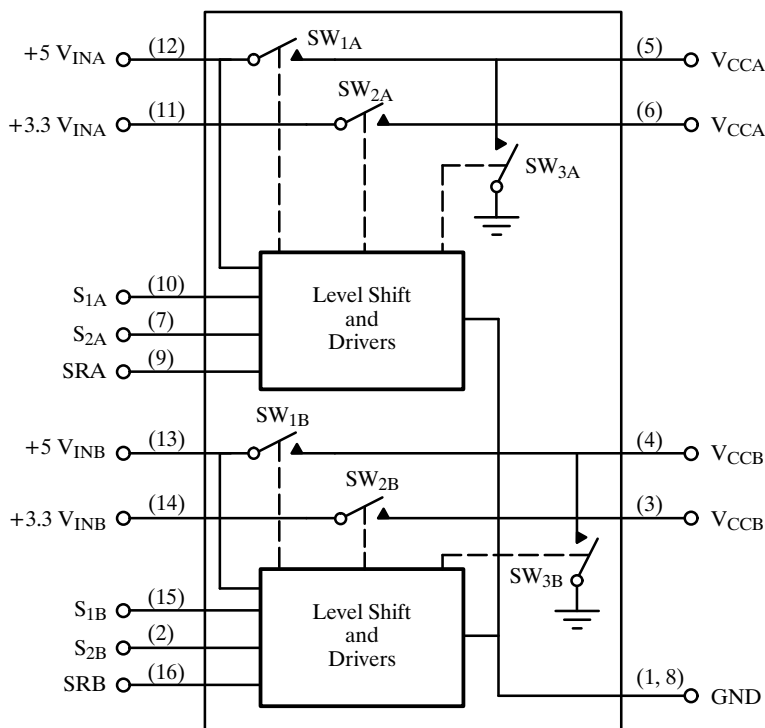

# Si9707DY

## Absolute Maximum Ratings

Voltages Referenced to Ground

+5 V <sub>INA</sub> , +5 V <sub>INB</sub> .....	7 V
+3.3 V <sub>INA</sub> , +3.3 V <sub>INB</sub> .....	7 V
S <sub>1A</sub> and S <sub>2A</sub> , S <sub>1B</sub> , S <sub>2B</sub> (CMOS Inputs) .....	7 V
All Pins .....	-0.5 V
I <sub>OUT</sub> V <sub>CCA</sub> <sup>a</sup> , I <sub>OUT</sub> V <sub>CCB</sub> <sup>b</sup> .....	4 A
PD Max <sup>c</sup> : (T <sub>A</sub> = 25°C) .....	1.65 W
(T <sub>A</sub> = 85°C) .....	0.65 W

Junction Temperature ..... 125°C

Thermal Ratings: R<sub>ΘJA</sub><sup>c</sup> ..... 60 °C/W

Notes

- Pins 5, 6 connected together externally.
- Pins 3, 4 connected together externally.
- Mounted on 1-IN<sup>2</sup>, FR4 PC Board.

## Recommended Operating Conditions

+5 V <sub>INA</sub> , +5 V <sub>INB</sub> (must be present) .....	5 V ± 10%
+3.3 V <sub>INA</sub> , +3.3 V <sub>INB</sub> .....	3.3 V ± 10%
C <sub>SRA</sub> , C <sub>SRB</sub> .....	33 nF
I <sub>OUT</sub> V <sub>CCA</sub> <sup>a</sup> , I <sub>OUT</sub> V <sub>CCB</sub> <sup>b</sup> .....	2 A

V<sub>CC</sub> Load Capacitance ..... 150 μF Max

Notes

- Pins 5, 6 connected together externally.
- Pins 3, 4 connected together externally.

## Specifications

Parameter	Symbol	Test Conditions Unless Otherwise Specified C <sub>SR</sub> = 33 nF, +5 V <sub>IN</sub> = 5 V +3.3 V <sub>IN</sub> = 3.3 V, Low ≤ 0.8 V, High ≥ 2.2 V		Limits -40 to 85°C			Unit
				Min <sup>a</sup>	Typ	Max <sup>a</sup>	
<b>Switch SW<sub>1A</sub>, SW<sub>1B</sub></b>							
On-Resistance	R <sub>ON</sub>	I = 500 mA, S <sub>1</sub> = High S <sub>2</sub> = Low	T <sub>A</sub> = 25°C		58	70	mΩ
			T <sub>A</sub> = 85°C		73	90	
Off Current (V <sub>CC</sub> )	I <sub>OFF</sub>	+5 V <sub>IN</sub> = 5.5 V, V <sub>CC</sub> = 0 V S <sub>1</sub> = S <sub>2</sub> = Low	T <sub>A</sub> = 25°C			1	μA
			T <sub>A</sub> = 85°C			10	
Rise Time	t <sub>S1(on)</sub>	S <sub>2</sub> = Low, See Figure 1		0.2	1.7	5	ms
Fall Time	t <sub>S1(off)</sub>			10	30	50	
<b>Switch SW<sub>2A</sub>, SW<sub>2B</sub></b>							
On-Resistance	R <sub>ON</sub>	I = 500 mA, S <sub>2</sub> = High S <sub>1</sub> = Low	T <sub>A</sub> = 25°C		44	55	mΩ
			T <sub>A</sub> = 85°C		55	70	
Off Current (+3.3 V <sub>IN</sub> )	I <sub>OFF</sub>	+3.3 V <sub>IN</sub> = 3.6 V, V <sub>CC</sub> = 0 V S <sub>1</sub> = S <sub>2</sub> = Low	T <sub>A</sub> = 25°C			1	μA
			T <sub>A</sub> = 85°C			10	
Rise Time	t <sub>S2(on)</sub>	S <sub>1</sub> = Low, See Figure 1		0.1	0.9	5	ms
Fall Time	t <sub>S2(off)</sub>			5	20	40	
<b>Switch SW<sub>3A</sub>, SW<sub>3B</sub></b>							
On-Resistance	R <sub>ON</sub>	I = 2 mA, S <sub>1</sub> = S <sub>2</sub> = Low	T <sub>A</sub> = 25°C		140	400	Ω
			T <sub>A</sub> = 85°C		200	500	
<b>Power Supply</b>							
+5 V <sub>IN</sub> Current Input (on)	I <sub>+5VIN(1)</sub>	S <sub>1</sub> = 0 V, S <sub>2</sub> = 3 V			20	50	μA
	I <sub>+5VIN(2)</sub>	S <sub>1</sub> = 3 V, S <sub>2</sub> = 0V			20	50	
+5 V <sub>IN</sub> Current Input (off)	I <sub>+5VIN(3)</sub>	S <sub>1</sub> = S <sub>2</sub> = 0 V			< 1	10	
<b>Switch Control Inputs S<sub>1X</sub>, S<sub>2X</sub></b>							
Input Voltage High	V <sub>I(H)</sub>	+5 V <sub>INX</sub> = 5.5 V		2.2	1.8		V
		+5 V <sub>INX</sub> = 4.5 V		2.2	1.6		
Input Voltage Low	V <sub>I(L)</sub>	+5 V <sub>INX</sub> = 5.5 V			1.6	0.8	
		+5 V <sub>INX</sub> = 4.5 V			1.4	0.8	
Input Current High	I <sub>I(H)</sub>	S <sub>1X</sub> , S <sub>2X</sub> = 5 V				1.0	μA
Input Current Low	I <sub>I(L)</sub>	S <sub>1X</sub> , S <sub>2X</sub> = GND		-1.0			

Notes

- The algebraic convention whereby the most negative value is a minimum and the most positive a maximum.

## Timing Waveforms

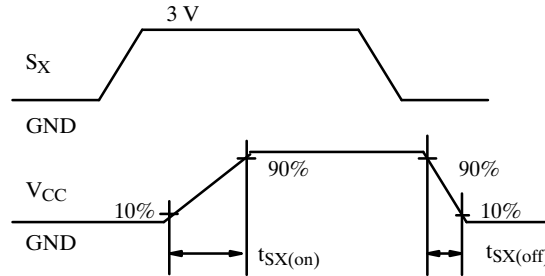
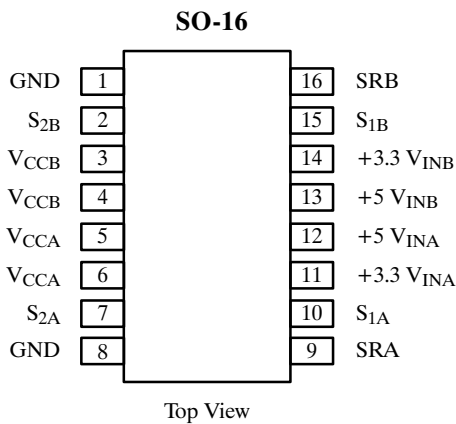

Figure 1. Switch Ramp Time

## Pin Configuration and Description



Function	Pin Number	Description
S <sub>1A</sub>	10	Control input for selecting +5 V <sub>INA</sub> to V <sub>CCA</sub> .
S <sub>1B</sub>	15	Control input for selecting +5 V <sub>INB</sub> to V <sub>CCB</sub> .
S <sub>2A</sub>	7	Control input for selecting +3.3 V <sub>INA</sub> to V <sub>CCA</sub> .
S <sub>2B</sub>	2	Control input for selecting +3.3 V <sub>INB</sub> to V <sub>CCB</sub> .
GND	1, 8	Ground connection.
V <sub>CCA</sub>	5, 6	Supply voltage to slot.
V <sub>CCB</sub>	3, 4	Supply voltage to slot.
+3.3 V <sub>INA</sub>	11	+3.3-V supply.
+3.3 V <sub>INB</sub>	14	+3.3-V supply.
+5 V <sub>INA</sub>	12	+5-V supply.
+5 V <sub>INB</sub>	13	+5-V supply.
SRA	9	Slew rate control pin.
SRB	16	Slew rate control pin.

## Truth Table

S <sub>1X</sub>	S <sub>2X</sub>	Switch 1X	Switch 2X	Switch 3X
0	0	Off	Off	On
0	1	Off	On	Off
1	0	On	Off	Off
1	1	Off	Off	On

Notes

- a. Switch 1 and 2 are delayed until after V<sub>CC</sub> is valid.
- b. Shaded lines are error conditions for PC Card applications.
- c. The smart switching of the Si9707 avoids potential host damage by defaulting to off during error conditions.

## Si9707DY

### Typical Characteristics (25°C Unless Otherwise Noted)

